

Read all the following information and instructions prior to installing and operating the equipment.
Failure to comply with these instructions could result in bodily injury or property damage.



TABLE OF CONTENTS

	Page No.
Introduction	1
Receiving, Handling & Inspection	2
Installation	2
Operation	3
Shut-Down	3
Basket Removal	3
Basket Replacement	4
Basket Cleaning	4
Recommended Spare Parts	4
Exploded Parts Drawing	4

INTRODUCTION

A simplex strainer is a device installed in a pipeline to remove dirt and other unwanted debris from fluids. Straining is accomplished by directing the fluid through sized openings in a basket. Simplex strainers are installed where fluid flow can be interrupted while the basket is removed for cleaning. Simplex strainers are designed to withstand the rated pressure of the piping system.

For additional information regarding Simplex Basket Strainers visit our website at www.eaton.com/filtration

RECEIVING, HANDLING, AND INSPECTION

Inspect strainer after unpacking for damage incurred during transit. Report any damage to the carrier immediately. If the strainer is not to be installed immediately, store indoors in a clean, dry environment.

Remove preservative with a solvent dampened cloth. Exercise care when using solvent.

Model 72 Simplex

Size	Material	End Connection	Seals	Pressure Rating
3/8" to 3"	Iron and Bronze	Threaded	Buna-N	200 psi @ 100°F
1" to 3"	Carbon Steel	Threaded	Buna-N	200 psi @ 100°F
1" to 3"	Stainless Steel	Threaded	Viton®	200 psi @ 100°F
1" to 8"	Iron	Flanged 125#	Buna-N	200 psi @ 100°F
1" to 8"	Bronze	Flanged 150#	Buna-N	200 psi @ 100°F
1" to 8"	Carbon Steel	Flanged 150#	Buna-N	200 psi @ 100°F
1" to 8"	Stainless Steel	Flanged 150#	Viton®	200 psi @ 100°F

Check to be sure the rated pressure and temperature on the strainer nameplate is not less than the maximum pressure and temperature of the installation. The rated pressure shown on the nameplate is the maximum pressure, including shock, at which the strainer may be operated.

Remove cover by turning T-bolt counterclockwise to release yoke, swing yoke clear of cover and remove cover. Check for and remove any foreign or loose materials that could be carried downstream when fluid is introduced into the strainer.

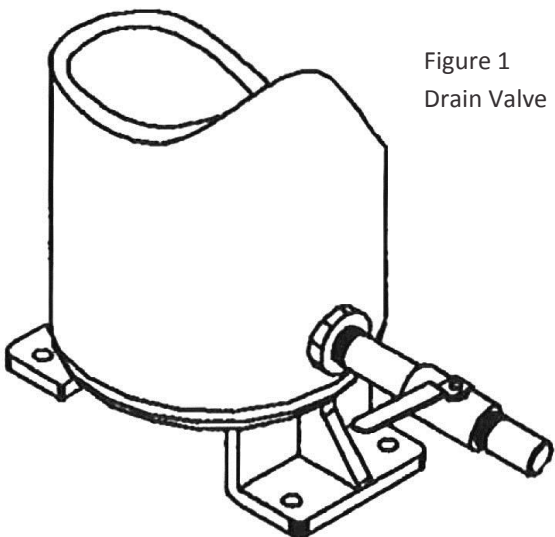

Figure 1
Drain Valve

Replace strainer cover and yoke and tighten T-bolt. The basket is held in place by pressure of the cover on the basket handle. If the basket is loose, spring the handle to a higher position to insure greater compression when the cover is seated.

INSTALLATION

Position the strainer in the line so that the fluid enters the connection marked "inlet."



CAUTION: Lift strainers with slings under the inlet and outlet connections. **DO NOT** lift the strainer by the yoke screw located on the strainer cover.

Be sure sufficient headroom is provided for easy removal of cover and basket.

Support the strainer in the line as follows:

4" size or under:

Use pipe supports under the process piping near inlet and outlet connections. Use care to prevent bending and expansion forces from acting on the nozzles.

5" size or larger:

Support on concrete or steel pads.

Connect the strainer to the line. Use same type flange faces. For example: **Do not** bolt raised face flanges to iron flat face flanges. Iron flanges must be flat face with full face gaskets.

Figure 2
Vent Piping

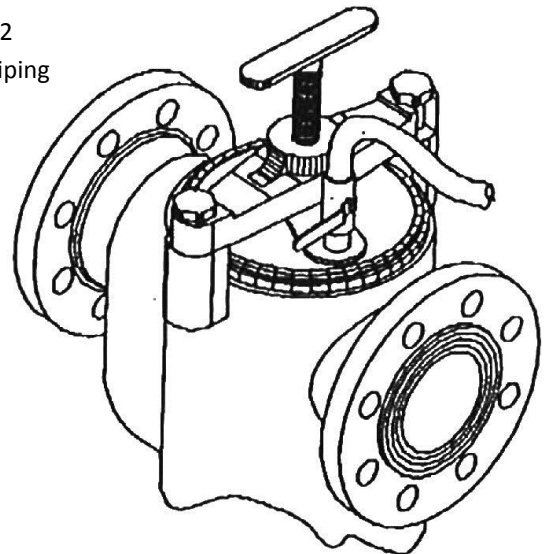

INSTALLATION (CONTINUED)

Cast strainers are subject to face-to-face variations due to shrinkage and machining tolerances.

Prefabricated piping systems must allow adjustment at the strainer connection.

If strainer has threaded connections follow proper threaded specifications. If strainer has weld connection follow proper ANSI weld specifications.

Be sure flange gaskets are in place and fasteners are tight.

It is recommended that the drain plug be removed and drain valve be installed at the bottom of the basket chamber as shown in Fig. 1.



CAUTION: A vent is required when fluids other than water and with temperatures in excess of 120° F are to be handled by the strainer. The vent must be piped to a safe discharge point to protect the operator. (See Fig.2). Wear protective clothing, which includes gloves, vests, and goggles when handling dangerous fluids.

Pressure gauges near the strainer inlet and outlet are recommended. Cleaning frequency is determined by the pressure drop across the strainer.

Flow Pattern

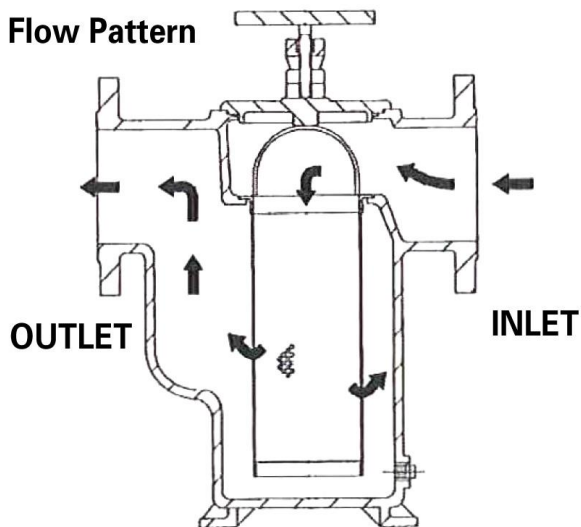

OPERATION

Open vent, if strainer is so equipped (See Fig. 2), to expel air from the strainer.

Slowly introduce fluid to be strained by opening the outlet valve first, followed by opening the inlet valve.



CAUTION: Start system GRADUALLY. This eliminates sudden shock to the strainer and other equipment in the line.

Close the vent when air is expelled and fluid begins to flow.

SHUT-DOWN

Tightly close valves on the inlet and outlet connections or the strainer. Open vent (See Fig. 2) and/or drain valve (See Fig.1) to relieve liquid pressure in the strainer.



CAUTION: DO NOT loosen cover while there is liquid or air flow from the vent.

BASKET REMOVAL

Follow shut-down procedure.

When pressure is relieved, loosen T-bolt. Drain fluid through bottom drain to a level below the basket seat.

Swing yoke clear of cover and remove cover and dirty basket.

BASKET REPLACEMENT

Place new or clean basket squarely on the basket seat. Be sure basket handle is sufficiently high to be compressed by strainer cover.

Inspect O-ring and seal surface: Clean seat or replace cover O-ring as necessary. Always keep spare O-rings in stock.

Replace cover, swing the yoke over the cover and make full contact with the yoke stud. Tighten the center T-bolt. If strainer is on suction service, fill basket chamber from outside source before installing cover.

Follow start-up procedure.

BASKET CLEANING

When to Clean

Clean basket when there is a 5 psi increase in pressure loss across the strainer.



CAUTION: To prevent damage to basket, DO NOT permit strainer pressure differential between inlet and outlet connections to exceed 20 psi.

How to Clean

Invert basket and wash out debris by directing a stream of air or water against the basket exterior. Use solvent if strained fluid is fuel or a chemical. Follow manufacturer's instruction when using a solvent to clean the basket.



NOTE: Do not allow basket contents to dry as this will make cleaning most difficult.

Inspect basket at each cleaning for holes or tears and replace as required.

SHUT-DOWN PERIODS

During shut-down periods drain the fluid and clean the basket.

RECOMMENDED SPARE PARTS

- 1 Eaton Replacement Basket
- 1 Eaton Replacement O-Ring

When ordering spare parts, specify all nameplate data as well as the description and quantity of parts.

Always use genuine Eaton replacement parts for guaranteed fit and performance.

Visit our web site, www.filtration.eaton.com for information about the hundreds of different types of Eaton Simplex Basket Strainers.

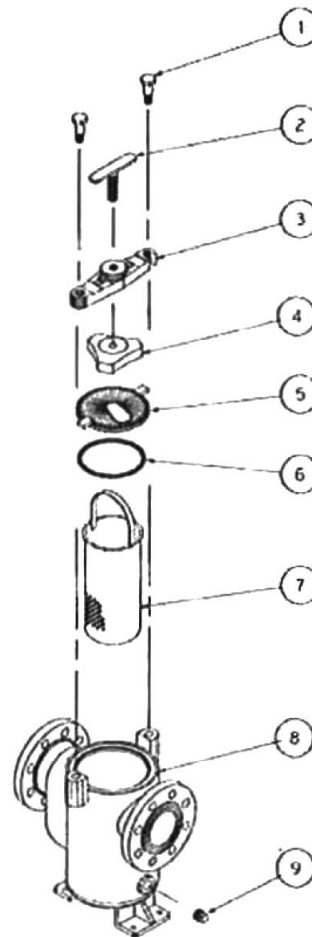

Item	Description
1	YOKE STUD
2	T-BOLT ASSEMBLY
3	YOKE
4	COVER CLAMP (sizes 4" to 6" only)
5	COVER
6	O-RING
7	BASKET
8	BODY
9	PIPE PLUG

Eaton
North America — HQ
70 Wood Avenue, South
2nd Floor
Iselin, NJ 08830

Toll Free: (800) 656-3344
(North America only)

Voice: (732) 767-4200
Fax: (952) 906-3706

Eaton
Europe/Africa/Middle East
Auf der Heide 2
53947 Nettersheim
Germany

Voice: +49-2486-809-0
Fax: +49-2486-809-800

Eaton
Brazil
Av. Julia Gaioli, 474 –
Bonsucesso
07251-500 – Guarulhos
Brazil

Voice: +55 (11) 2465-8822
Fax: +55 (11) 2465-8884

Eaton
China
No.3, Lane 280, Linhong Road
Changning District, 200335
Shanghai, P.R. China

Voice: +86-21-5200-0099
Fax: +86-21-5200-0400

Eaton
Singapore
4 Loyang Lane #04-01/02
Singapore 508914

Voice: +65-6825-1668
Fax: +65-6825-1639

For more information, please
e-mail us at
filtrationinfo@eaton.com
or call 732-767-4200.

WARRANTY

All products manufactured by Seller are warranted against defects in material and workmanship under normal use and service for which such products were designed for a period of eighteen (18) months after shipment from our factory or twelve (12) months after start-up, whichever comes first. OUR SOLE OBLIGATION UNDER THIS WARRANTY IS TO REPAIR OR REPLACE, AT OUR OPTION, ANY PRODUCT OR ANY PART OR PARTS THEREOF FOUND TO BE DEFECTIVE. SELLER MAKES NO OTHER REPRESENTATION OR WARRANTY, EXPRESS OR IMPLIED, INCLUDING, BUT NOT LIMITED TO, ANY IMPLIED WARRANTY OF MERCHANTABILITY OR FITNESS FOR A PARTICULAR PURPOSE. WE SHALL NOT BE LIABLE FOR CARTAGE, LABOR, CONSEQUENTIAL DAMAGES OR CONTINGENT LIABILITIES. OUR MAXIMUM LIABILITY SHALL NOT IN ANY EVENT EXCEED THE CONTRACT PRICE FOR THE PRODUCT.